



SOLA BY SKYSPAN

ASSEMBLY INSTRUCTIONS

SOLA BREEZE UMBRELLA

3.0 x 3.0m Square



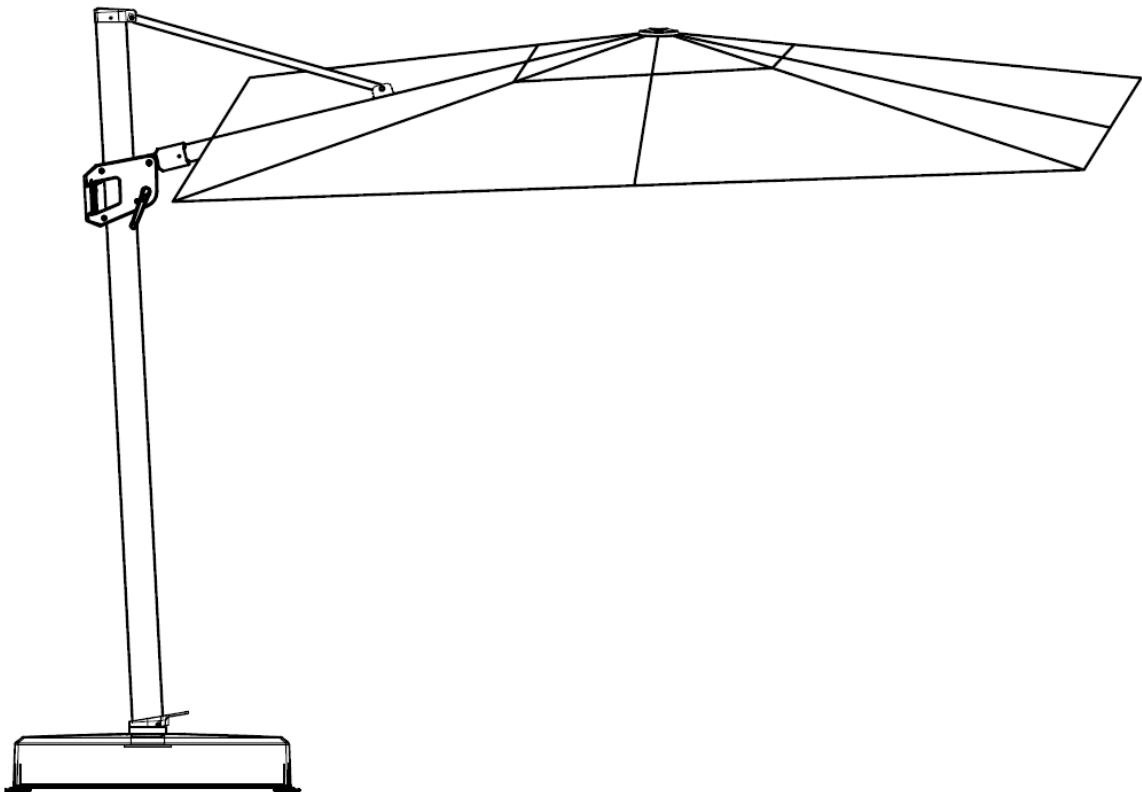







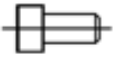

3.5m Octagonal

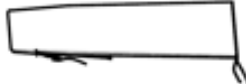

www.skyspanshade.com.au | sales@skyspanshade.com.au | +61 (07) 3804 6288

CONTENTS

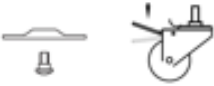
Note this includes parts K-O for the portable base. The 40 x 40 x 4cm pavers are not included and can be bought at a local DIY centre.

	Item	Description	Quantity
A		Umbrella	1
B		Handle	1
C		Bolt M10 x 20mm	4
D		Washer 10mm	4
E		Allan Key 8mm	1
F		Bolt M8 x 16mm	2
G		Washer 8mm	2
H		Allan Key 6mm	1
J		Umbrella Cover	1
K		Aluminium Base Cover	1
L		Steel Base	1
M		Levelling Feet or Lockable Wheels	4
N		Spanner	1
O		40 x 40 x 4cm Pavers (Not Included)	12

ASSEMBLY INSTRUCTIONS

Note this is based on attaching to the portable base. Other bases are similar - refer to instructions included with the base.

①

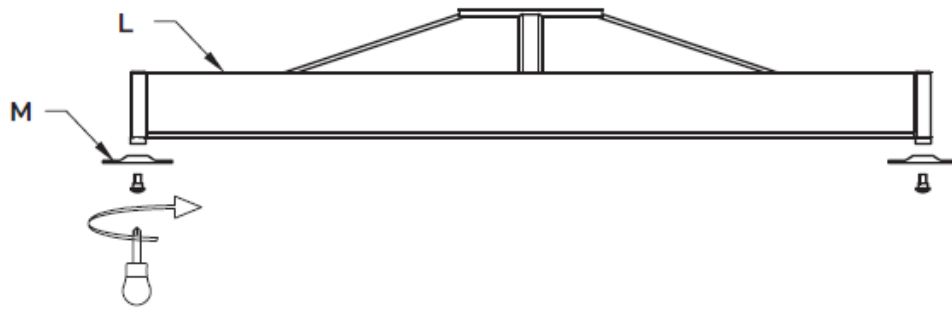

②

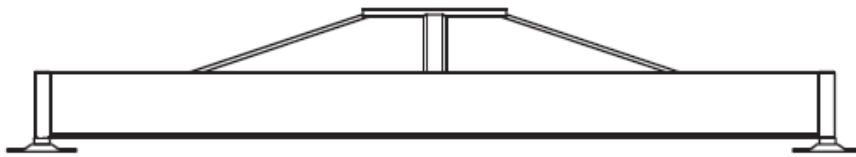

③

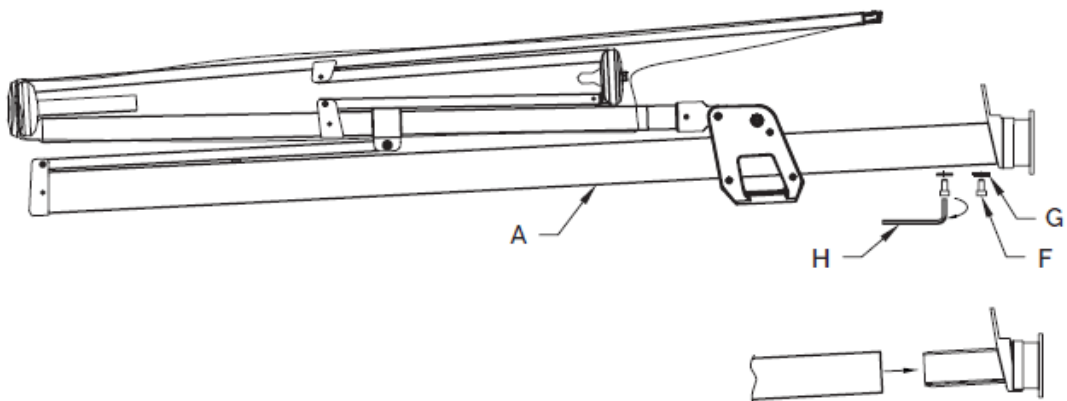

④

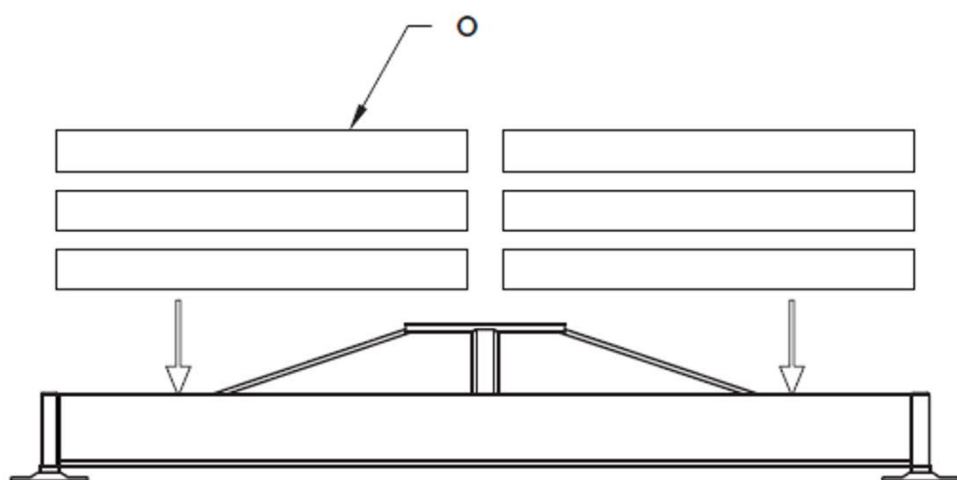

⑤

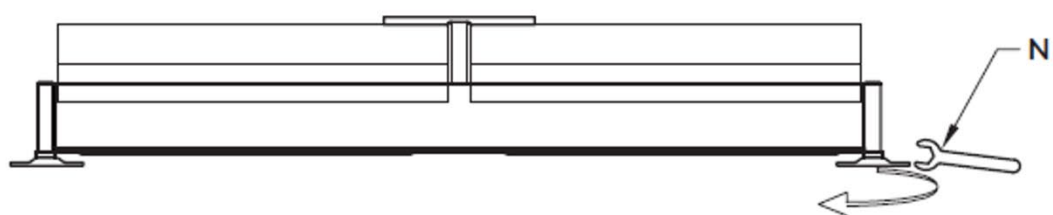

⑥

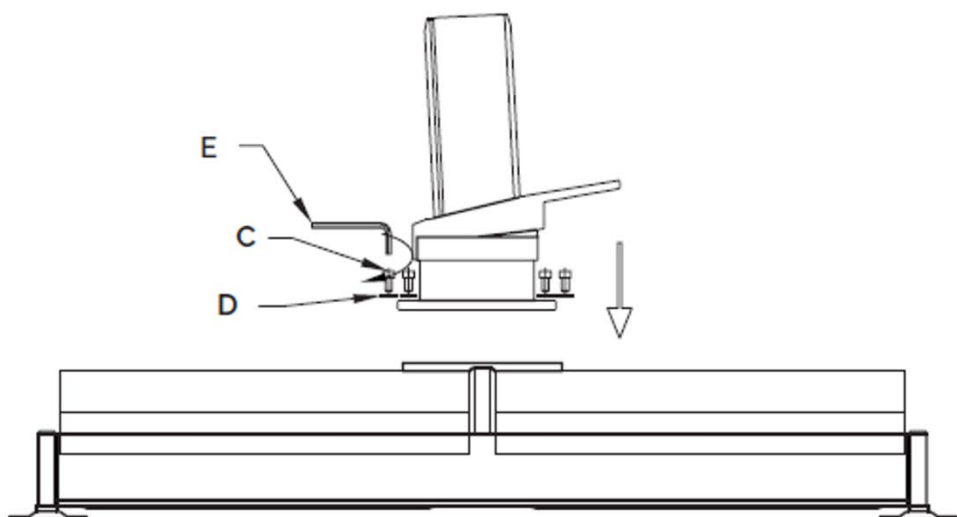



⑦

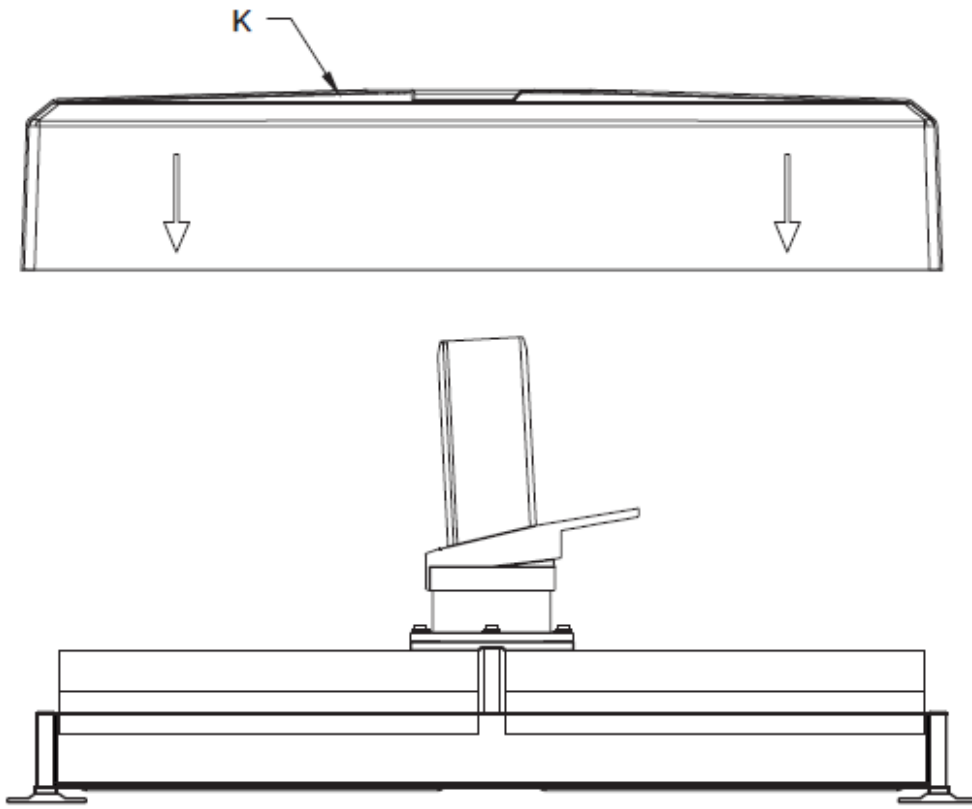

⑧

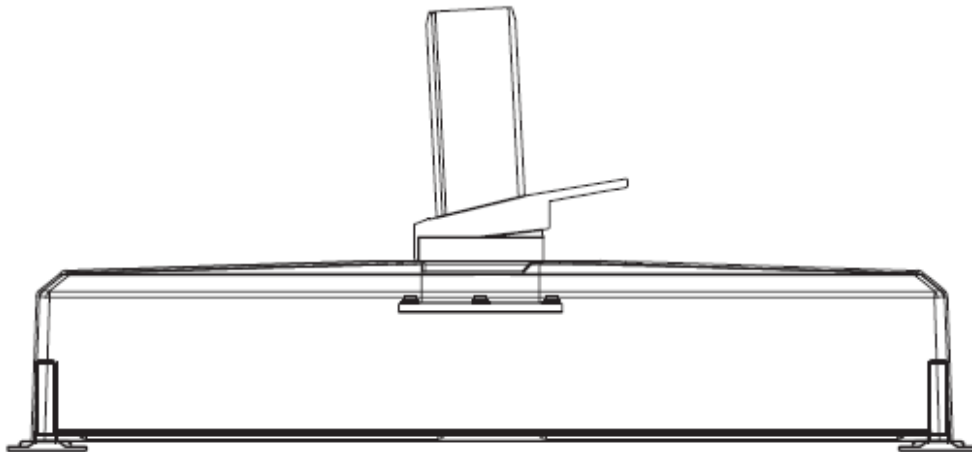

9

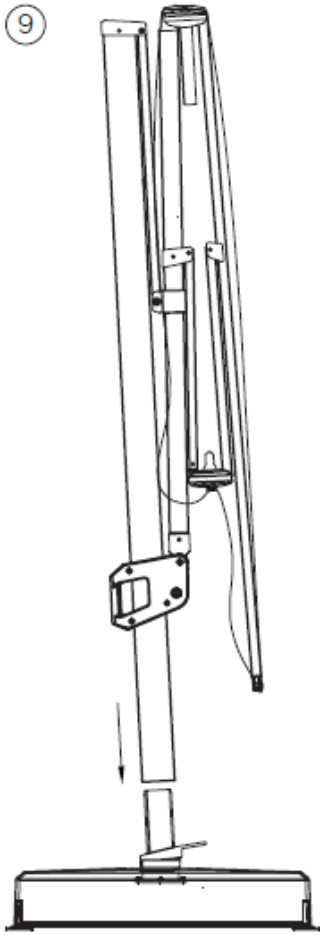

10

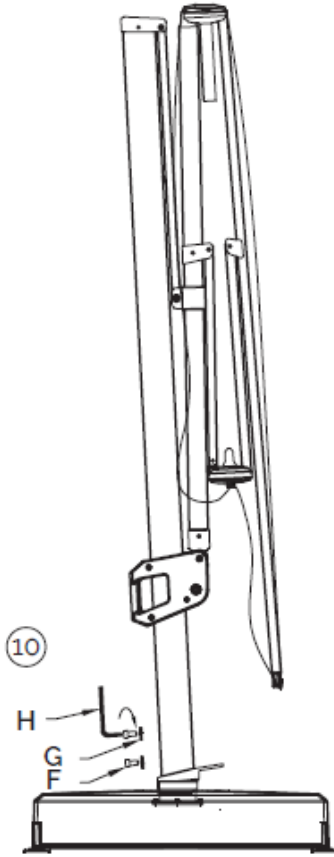

11

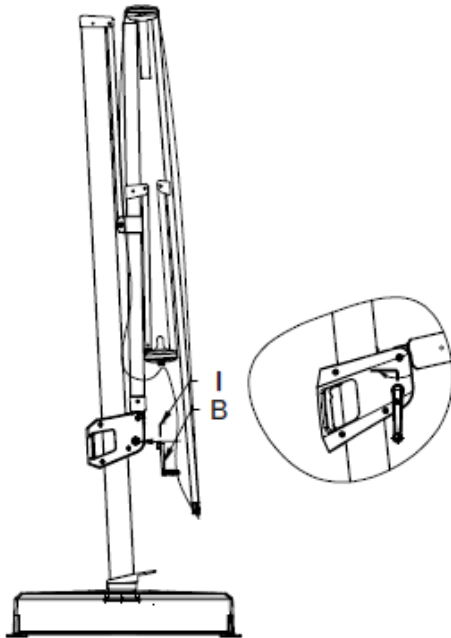

12

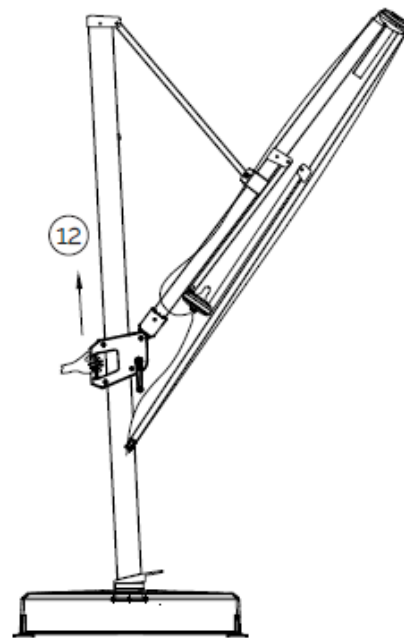

13

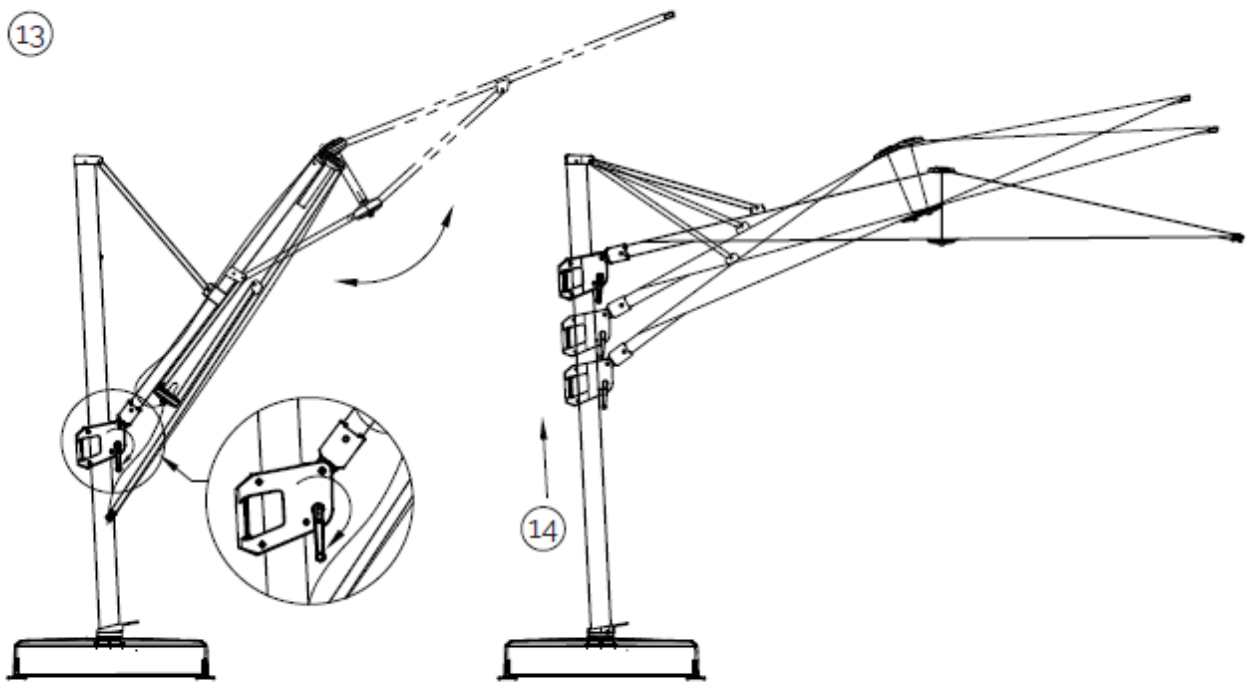

15

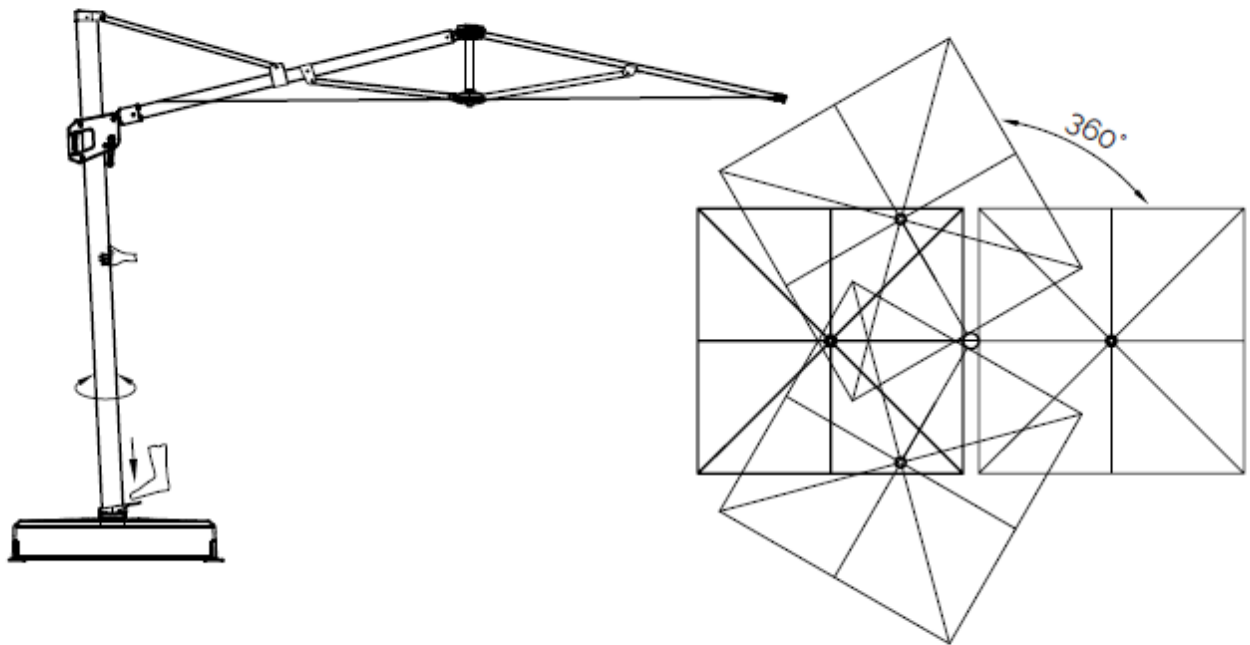

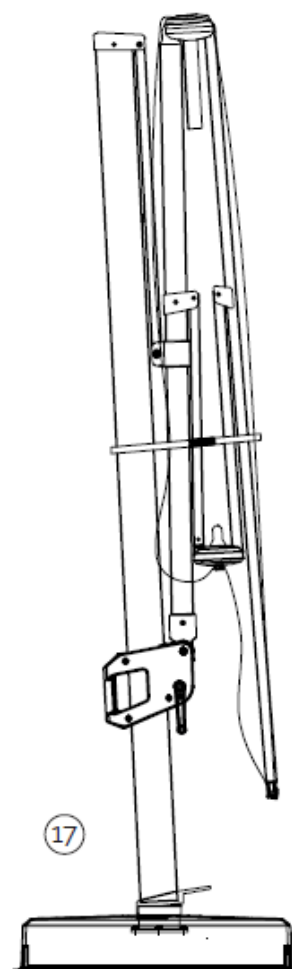
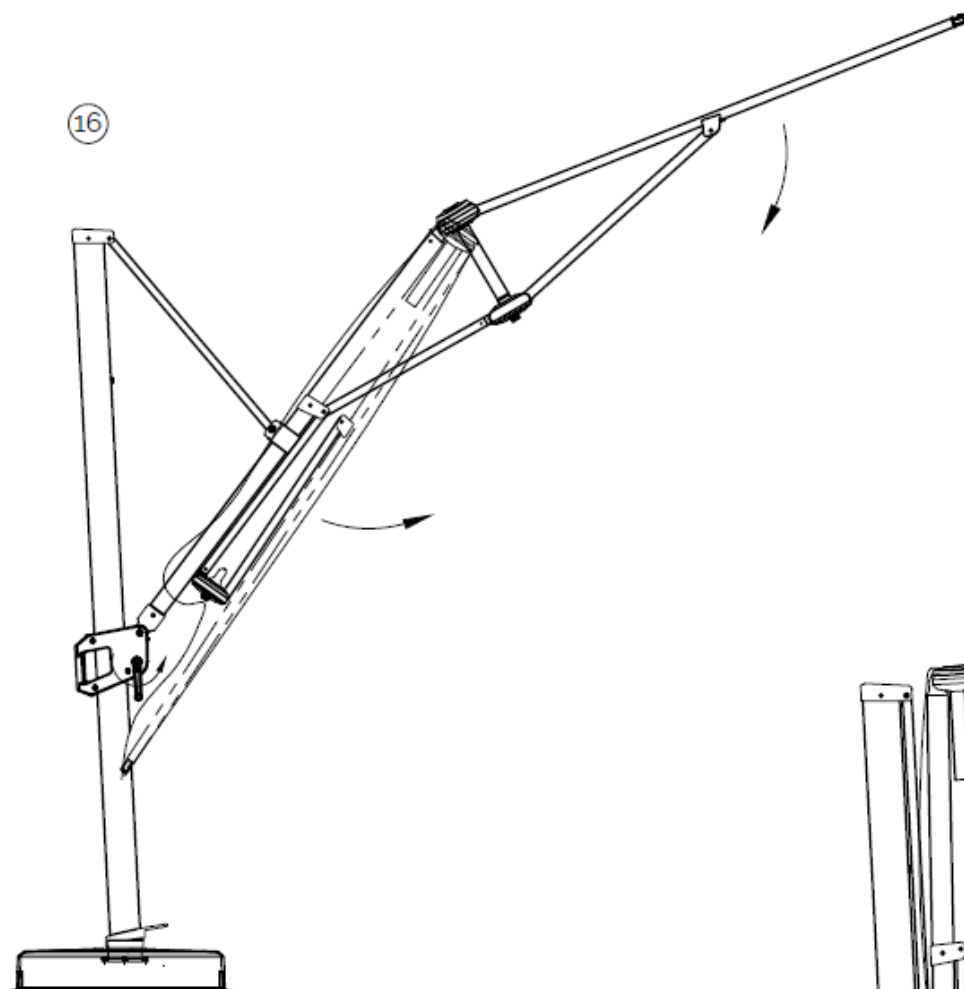



18

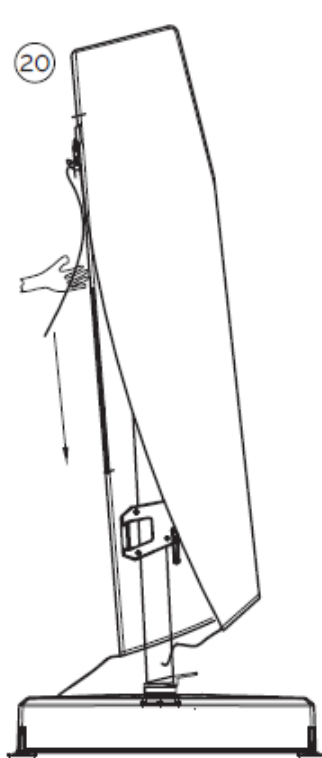
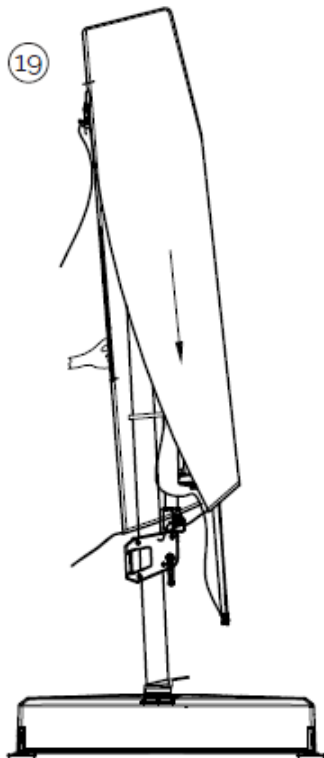
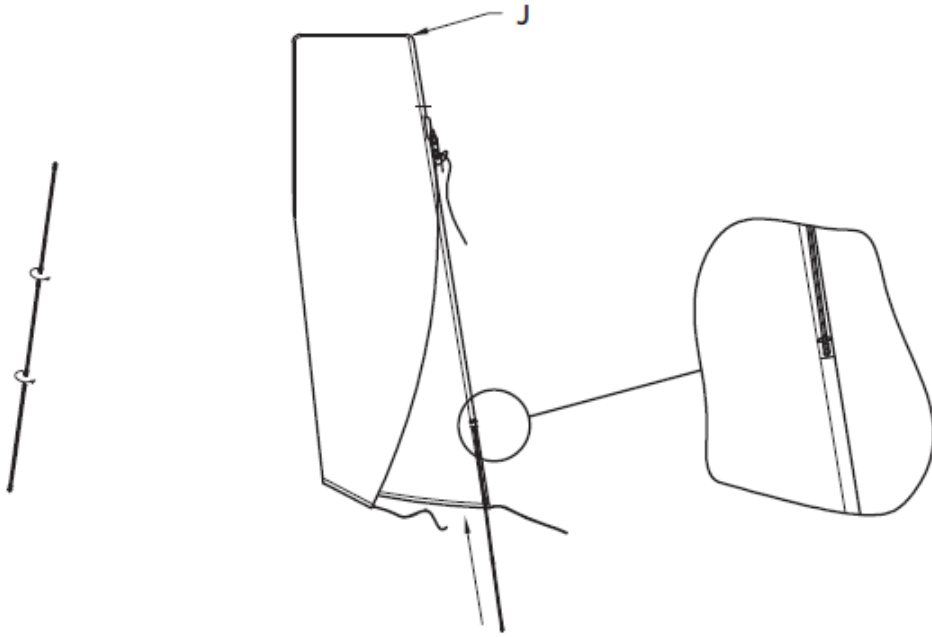

 SOLA BY SKYSPAN



SOLA BY SKYSPAN

www.skyspanshade.com.au | sales@skyspanshade.com.au | +61 (07) 3804 6288